

# CHIEF PLENTY COUPS HOUSE FOUNDATION STABILIZATION RE-BID

CHIEF PLENTY COUPS STATE PARK  
PRYOR, MONTANA  
AUGUST 24, 2022  
100% CONSTRUCTION DOCUMENTS  
FWP PROJECT NUMBER: 7196121



CHIEF PLENTY COUPS HOUSE  
CURRENT VIEW FROM SOUTH

1  
A1

NTS

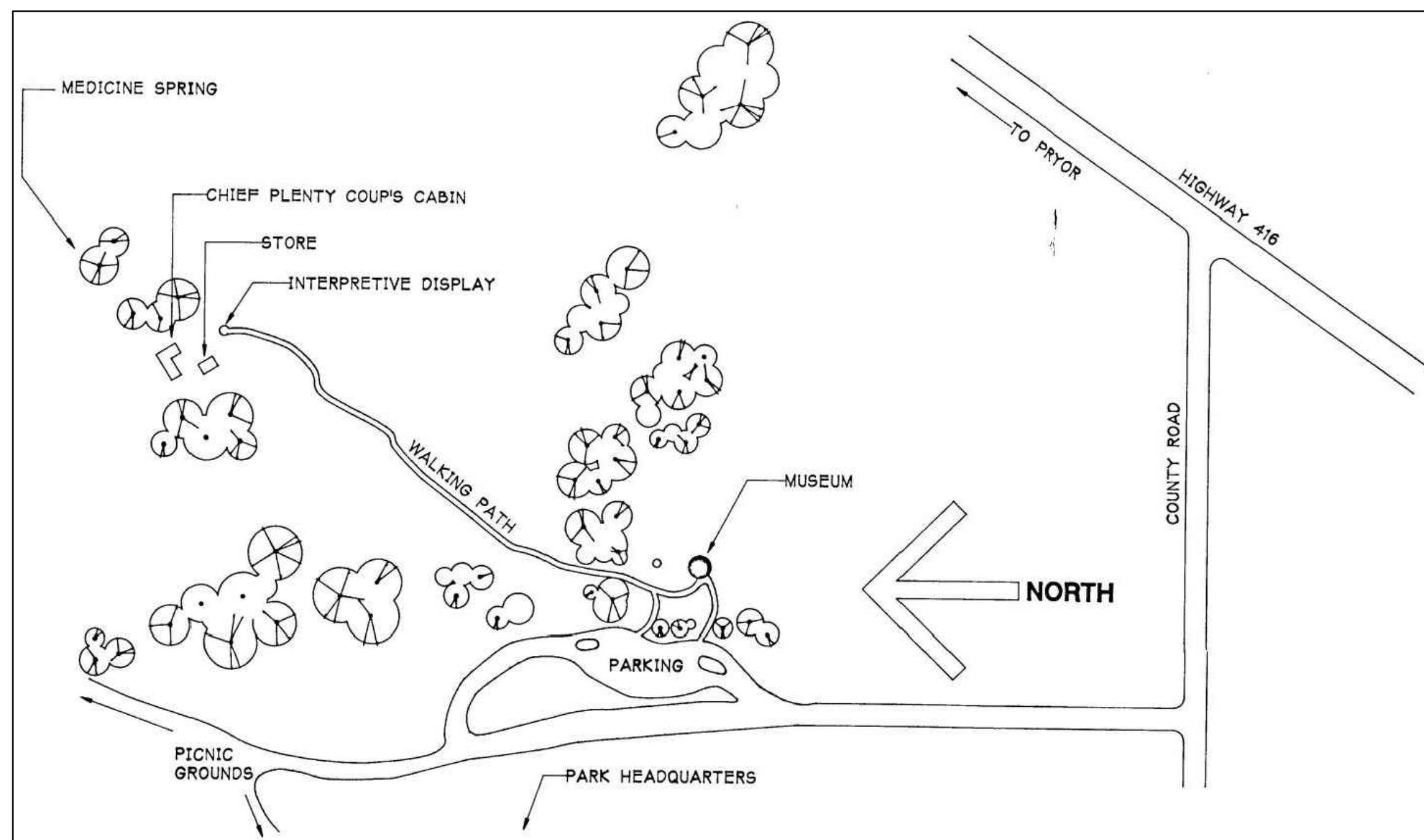

1993 VICINITY MAP

2  
A1

NTS



OWNER:  
MONTANA FISH, WILDLIFE & PARKS  
SITE CONTACT: AARON KIND  
EMAIL: AKind@mt.gov  
PHONE: (406) 252-1289

PRIMARY CONTACT: RANDI ROGNLIE, PROJECT MANAGER, DESIGN &  
CONSTRUCTION SECTION  
EMAIL: Randi.Rognlie@mt.gov  
PHONE: (406) 841-4019

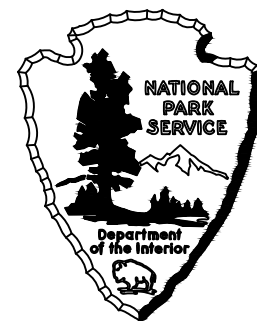

MONTANA FISH, WILDLIFE AND PARKS HERITAGE PROGRAM SPECIALIST:  
BRENNAMOLONEY  
EMAIL: brennamoloney@mt.gov  
PHONE: (406) 594-4322

NPS CONTRACTING OFFICER'S REPRESENTATIVE: THOMAS KEOHAN,  
HISTORICAL ARCHITECT  
PHONE: (303) 969-2897



cushingterrell.com  
800.757.9522

ARCHITECT:  
CUSHING TERRELL  
PROJECT MANAGER: DAVID MITCHELL  
EMAIL: DAVIDMITCHELL@CUSHINGTERRELL.COM  
PHONE: (406) 407-7771

PRIMARY CONTACT: CHELSEA HOLLING  
EMAIL: CHELSEAHOLLING@CUSHINGTERRELL.COM  
PHONE: (406) 922-7135

## INDEX

SHEET	SUB SHEET	TITLE OF SHEET
1	A1	COVER SHEET
2	A2	CHIEF'S HOUSE & STORE
3	A3	FOUNDATION PLAN
7	A7	CHIEF'S HOUSE & STORE PHOTOS DETAILS

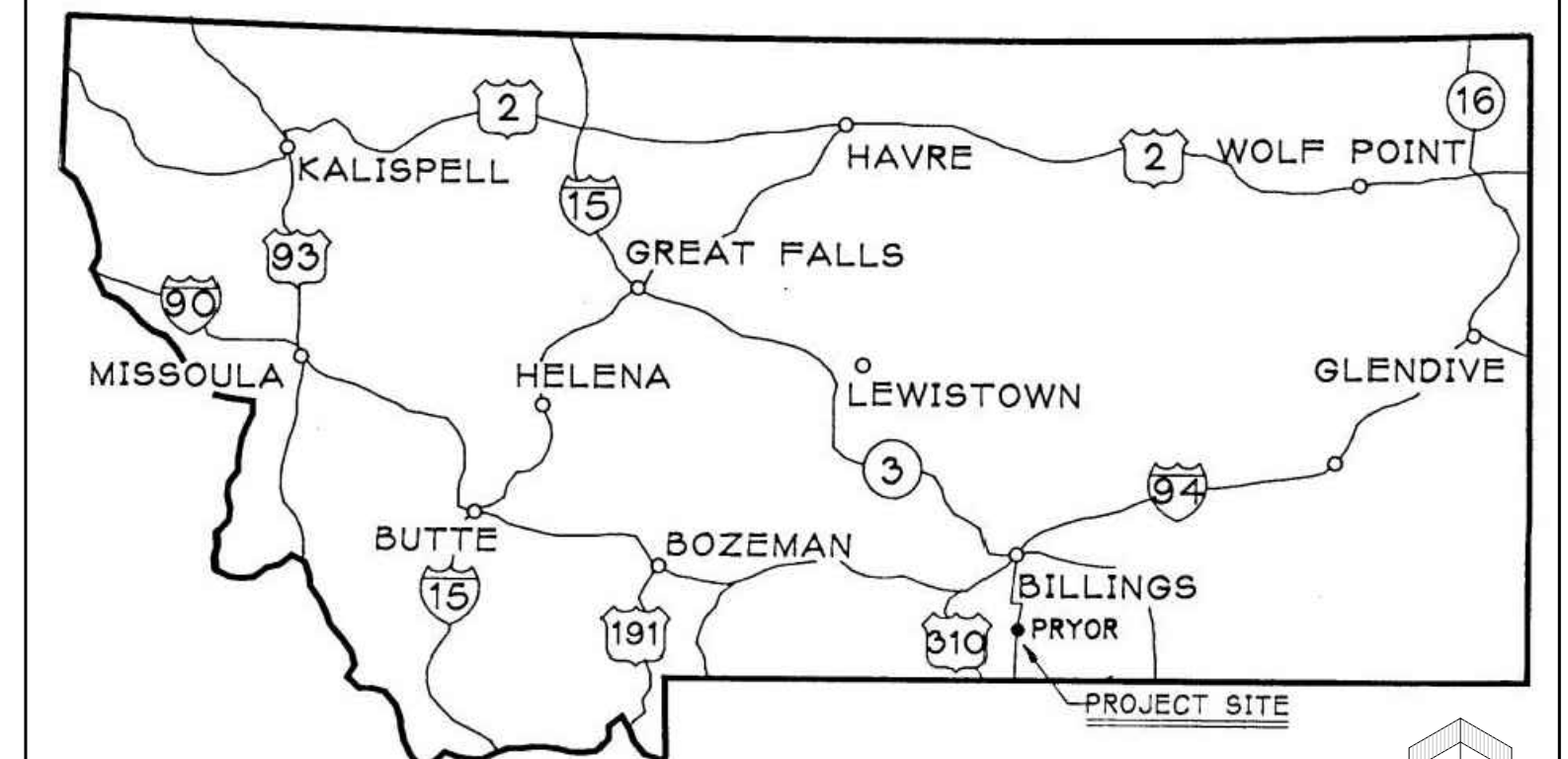

STATE MAP PRYOR MONTANA FROM 1993 DRAWINGS

## SPECIAL REQUIREMENTS

- COORDINATE ALL WORK WITH FWP HERITAGE RESOURCE PROGRAM ARCHEOLOGIST. ALL SOIL WORK SHALL BE MONITORED WITH ARCHEOLOGIST. IF CONTRACTOR DISCOVERS ANY ARTIFACTS OR HUMAN REMAINS, CONTRACTOR SHALL IMMEDIATELY STOP WORK & CONTACT THE ARCHEOLOGIST. CONTACT BRENNAMOLONEY, FWP HERITAGE RESOURCE SPECIALIST (SEE SHEET 1).
- CONTRACTOR MUST COORDINATE WITH THE CULTURAL SURVEYOR. EXCAVATION WORK ON THE HOUSE CANNOT EXCEED 7, 8-HOUR CONSECUTIVE OR NON-CONSECUTIVE DAYS. FWP'S QUALIFIED CULTURAL CONSULTANT OR FWP'S HERITAGE SPECIALIST MUST BE ON-SITE DURING ANY EXCAVATION.
- ANY CHANGE, ALTERATION OR AMENDMENT TO THE WORK SPECIFIED IN THESE DOCUMENTS REQUIRES REVIEW AND APPROVAL BY THE FWP AND NATIONAL PARK SERVICE.
- REMOVE & REINSTALL DOWNSPOUTS AS REQ'D TO DO THE WORK.

## GENERAL PROJECT NOTES

- THIS PROPERTY IS LISTED AS A NATIONAL HISTORIC LANDMARK. ALL WORK SHALL CONFORM TO THE SECRETARY OF INTERIOR'S STANDARDS FOR THE PRESERVATION OF HISTORIC PROPERTIES.
- COPIES OF DRAWINGS HAVE BEEN EXTRACTED FROM 1993 DRAWINGS BY PRAIRIE WIND ARCHITECTURE, AS NOTED.
- GROUND PENETRATING RADAR ANALYSIS WAS PERFORMED BY CTA ENVIRONMENTAL ON NOVEMBER 2, 2018. THE RESULTANT REPORT HAS BEEN USED TO ASCERTAIN FOUNDATION CONDITIONS AND WILL BE INCLUDED IN THE PROJECT MANUAL.
- THIS PROJECT IS FUNDED BY THE NATIONAL PARK SERVICE'S SAVE AMERICA'S TREASURES PROGRAM.
- COORDINATE ALL WORK WITH THE FWP HERITAGE RESOURCE PROGRAM ARCHEOLOGIST.
- ON NOVEMBER 2, 2018 CTA DOCUMENTED MOISTURE CONTENT OF SILL LOGS & LOGS IN VISIBLY POOR CONDITION. THIS INFORMATION HAS INFORMED THE SCOPE OF WORK AND WILL BE SUBMITTED TO FWP FOR FUTURE MONITORING EFFORTS.
- THIS PROJECT'S SCOPE OF WORK INCLUDES FOUNDATION REPAIRS & STABILIZATION, REGRADING, MINIMAL EAVE/GUTTER WORK, ROOF REPAIRS AND REPLACEMENT, LOG REPAIR AND REPLACEMENT (AS NEEDED) WINDOW REPLACEMENT, & CHINKING/ DAUBING.
- CONTRACTOR SHALL PROTECT EXISTING SOILS & VEGETATION. NO VEHICLES OR EQUIPMENT SHALL BE RUN OVER THE LAWN WITHOUT PROVIDING SHEETS OF PLYWOOD UNDERNEATH TO DISTRIBUTE THE WEIGHT & PROTECT THE VEGETATION. CONTRACTOR SHALL REVIEW ANY SUCH OVER-THE-LAWN ACTIVITY WITH FWP PRIOR TO THE ACTIVITY. NO VEHICLE PARKING ON THE LAWN.
- THIS BUILDING WILL NOT BE OCCUPIED DURING THE CONSTRUCTION PERIOD.
- THE CONTRACTOR SHALL COORDINATE ALL WORK PERFORMED BY OTHERS TO ENSURE SMOOTH UNINTERRUPTED CONSTRUCTION.
- THE CONTRACTOR SHALL PROTECT ALL SURFACES & ITEMS TO REMAIN.
- ALL WORK UNDER THIS CONTRACT SHALL COMPLY WITH ALL APPLICABLE CODES, ORDINANCES, & REGULATIONS INCLUDING BUT NOT LIMITED TO THE 2021 INTERNATIONAL EXISTING BUILDING CODE, ALL FWP GUIDELINES, & SECRETARY OF THE INTERIORS STANDARDS.
- DO NOT SCALE THE DRAWINGS. VERIFY ALL DIMENSIONS IN THE FIELD. CONTACT THE ARCHITECT FOR FURTHER CLARIFICATION IF NEEDED.
- THE CONTRACTOR & ALL SUB-CONTRACTORS SHALL VERIFY ALL EXISTING CONDITIONS PRIOR TO THE START OF CONSTRUCTION. NOTIFY THE PARK IMMEDIATELY OF ANY INCONSISTENCIES OR DISCREPANCIES IN THE DRAWINGS &/OR SPECIFICATIONS COMPARED TO EXISTING CONDITIONS.
- PROVIDE DEMOLITION & PATCHING NOT SHOWN BUT REQUIRED FOR THE INSTALLATION OF NEW DETAILS OR AS REQUIRED FOR THE WORK.
- ALL WORK SHALL BE PERFORMED IN A MANNER SO AS NOT TO INCREASE/CAUSE A FIRE HAZARD.
- THE CONTRACTOR SHALL PROVIDE PROTECTION WHERE NECESSARY TO PROTECT THE PUBLIC & ADJACENT AREAS OF THE BUILDING DURING CONSTRUCTION AS DIRECTED BY THE OWNER.
- CONTRACTOR SHALL PROVIDE TEMPORARY STRUCTURAL BRACING AS REQUIRED DURING WORK.
- HATCHES INDICATE NEW MATERIALS. IF COMPONENT IS NOT HATCHED, IT IS AN EXISTING CONDITION TO REMAIN.

THE CHIEF PLENTY COUPS STATE PARK IS DESIGNATED A NATIONAL HISTORIC LANDMARK FOR ITS ARCHITECTURAL AND HISTORIC SIGNIFICANCE. IT IS CONSIDERED TO HAVE IRREPLACEABLE CULTURAL, MATERIAL, AND AESTHETIC VALUE. THE WORK IS FUNDED IN PART BY THE HISTORIC PRESERVATION FUND, ADMINISTERED BY THE NATIONAL PARK SERVICE, DEPARTMENT OF THE INTERIOR. THE FUNDING OF WHICH IS SUBJECT TO HAVING ALL WORK ITEMS MEET THE SECRETARY OF THE INTERIOR'S STANDARDS FOR THE TREATMENT OF HISTORIC PROPERTIES.



- GENERAL SHEET NOTES
1. SEE GENERAL PROJECT NOTES ON COVER SHEET.
  2. SEE OTHER SHEETS IN THIS SET FOR ADDITIONAL INFORMATION.
  3. SENSITIVE CULTURAL RESOURCES ARE KNOWN TO BE PRESENT. DO NOT DISTURB AND ALERT MONITORING ARCHEOLOGIST IF ANY ARTIFACTS OR OTHER CULTURAL ITEMS ARE ENCOUNTERED.
  4. TRIBAL AND HERITAGE ARCHEOLOGISTS TO BE ON-SITE DURING ALL GROUND DISTURBANCES.
  5. ALL GRADING TO BE DONE BY HAND.
  6. FLAG SPRINKLER SYSTEM LINES AND HEADS PRIOR TO ANY WORK TO AVOID DAMAGING THE SYSTEM.

- ITEMIZED CONSTRUCTION NOTES
1. STABILIZE AND REPAIR EXISTING SUB-GRADE FOUNDATION WALL. GROUND PENETRATING RADAR EVIDENCE SHOWS THAT EXISTING FOUNDATION WALL HAS SETTLE &/OR MISSING IN AREAS.
  2. EXISTING FOUNDATION WALL TO REMAIN.
  3. TEMPORARILY SHORE PORCH ROOF TO ALLOW FOR SPEC'D REPAIRS.
  4. REMOVE EXISTING CONCRETE PIER & STONE CAP. SALVAGE STONE FOR REUSE. PROVIDE NEW CONCRETE PIER & REINSTALL STONE CAP.
  5. REPLACE BOTTOM 3 1/2" OF EXISTING PORCH POST. MOUNTING BOTTOM PORTION 1/2" MIN. ABOVE FLOOR BOARD. DETAIL PER 7/A7. PAINT FULL HEIGHT OF POST TO MATCH EXISTING.
  6. REMOVE EXISTING WOOD PLANK FLOOR BOARDS & REINSTALL WITH MATCHING (SAME THICKNESS & WIDTH, ROUGH SAWN 1 x 8), INSTALLED RUNNING N/S, MATCHING ORIGINAL PORCH DESIGN.
  7. REMOVE FULL LENGTH OF EXISTING 2x FLOOR DECK FASCIA & CONFIRM CONDITION OF 2x RIM JOIST. ALLOW TIME FOR ARCHITECT TO REVIEW. PROVIDE 2x DECK FASCIA.
  8. PROVIDE PRESSURE TREATED WOOD BLOCK SUPPORT BELOW FLOORING BELOW EACH PORCH POST. COORDINATE WITH OTHER WORK AT FLOORING & POSTS.
  9. FOR FULL LENGTH OF PORCH, REMOVE LOOSE LEAVES & VEGETATION. REMOVE RAISED GRADE BY HAND. CONSTRUCT NEW FINISHED GRADE BY HAND, AWAY FROM DECK FASCIA AT 5% SLOPE. NEW FINISHED GRADE SHALL NOT CAUSE ANY STORM PONDING OR EROSION CHANNELS. COORDINATE WITH TRIBAL AND HERITAGE ARCHEOLOGIST.
  10. REMOVE EXISTING WIRE SCREENING BETWEEN STONE PIERS OF PORCH (FULL LENGTH), PROVIDE WIRE SCREENING OF SMALLER GRID.
  11. REMOVE EXISTING GUTTER, LOWEST TWO ROOF DECK BOARDS, & ROOFING AS REQ'D TO ACCESS. PROVIDE LOWER DECK BOARDS, SELF-ADHERED MEMBRANE, & DRIP EDGE. PROVIDE MATCHING ROOF SHINGLES & RE-HANG EXISTING GUTTER AT LEAST 1" BELOW BOTTOMMOST ROOF/EAVE SHINGLE.
  12. REMOVE EXISTING GUTTER & RE-MOUNT AT LEAST 1" BELOW BOTTOMMOST ROOF/EAVE SHINGLE.
  13. REMOVE RAISED GRADE BY HAND. CONSTRUCT NEW FINISHED GRADE BY HAND, AWAY FROM BUILDING AT 5% SLOPE FOR 10 FEET ON NORTH SIDE OF BUILDING AND 5% SLOPE FOR 10 FEET ON WEST SIDE OF BUILDING. NEW FINISHED GRADES SHALL NOT CAUSE ANY STORM PONDING OR EROSION CHANNELS. COORDINATE WITH TRIBAL AND HERITAGE ARCHEOLOGIST.
  14. PROVIDE LONGER (BY 6'-0" +/-) EXTENSION TO DOWNSPOUT, TO KEEP RUN-OFF AWAY FROM HOUSE.
  15. REMOVE EXISTING SILL LOG & PROVIDE REPLICA SILL LOG. TREAT WITH 3/4" BORATE RODS @ 14" O.C.
  16. PROVIDE STONE CAP TO CORNER FOUNDATION.
  17. GRIND/SHAPE CONCRETE FROM FULL LENGTH OF GAP BETWEEN SILL LOG & STONE FOUNDATION TO SLOPE DOWN AWAY FROM LOG.
  18. CONSTRUCT SWALE AT 2% SLOPE.
  19. REMOVE EXISTING PORCH BOARDS AND PREPARE FOR REINSTALLATION. ROTATE BOARDS 90 DEGREES TO RUN PERPENDICULAR TO WALL PLANE AND INSTALL AS SHOWN IN HISTORIC PHOTOGRAPHS.
  20. CAREFULLY REMOVE INTERIOR CHINKING. INSTALL NEW CHINKING TO MATCH EXISTING COLOR AND COMPOSITION.
  21. TEMPORARILY SHORE STORE TO ALLOW FOR SPEC'D REPAIRS.
  22. REMOVE EXISTING HOLLOW CLAY TILE FOUNDATION. PROVIDE PRESSURE TREATED WOOD BLOCKING SUPPORT BELOW SILL LOG. PROVIDE NEW CONCRETE PIERS BELOW BLOCKING. COORDINATION WITH OTHER WORK. (SEE PIER DETAIL.)
  23. REMOVE EXISTING SILL LOG & PROVIDE REPLICA SILL LOG. TREAT WITH 3/4" BORATE RODS @ 14" O.C.

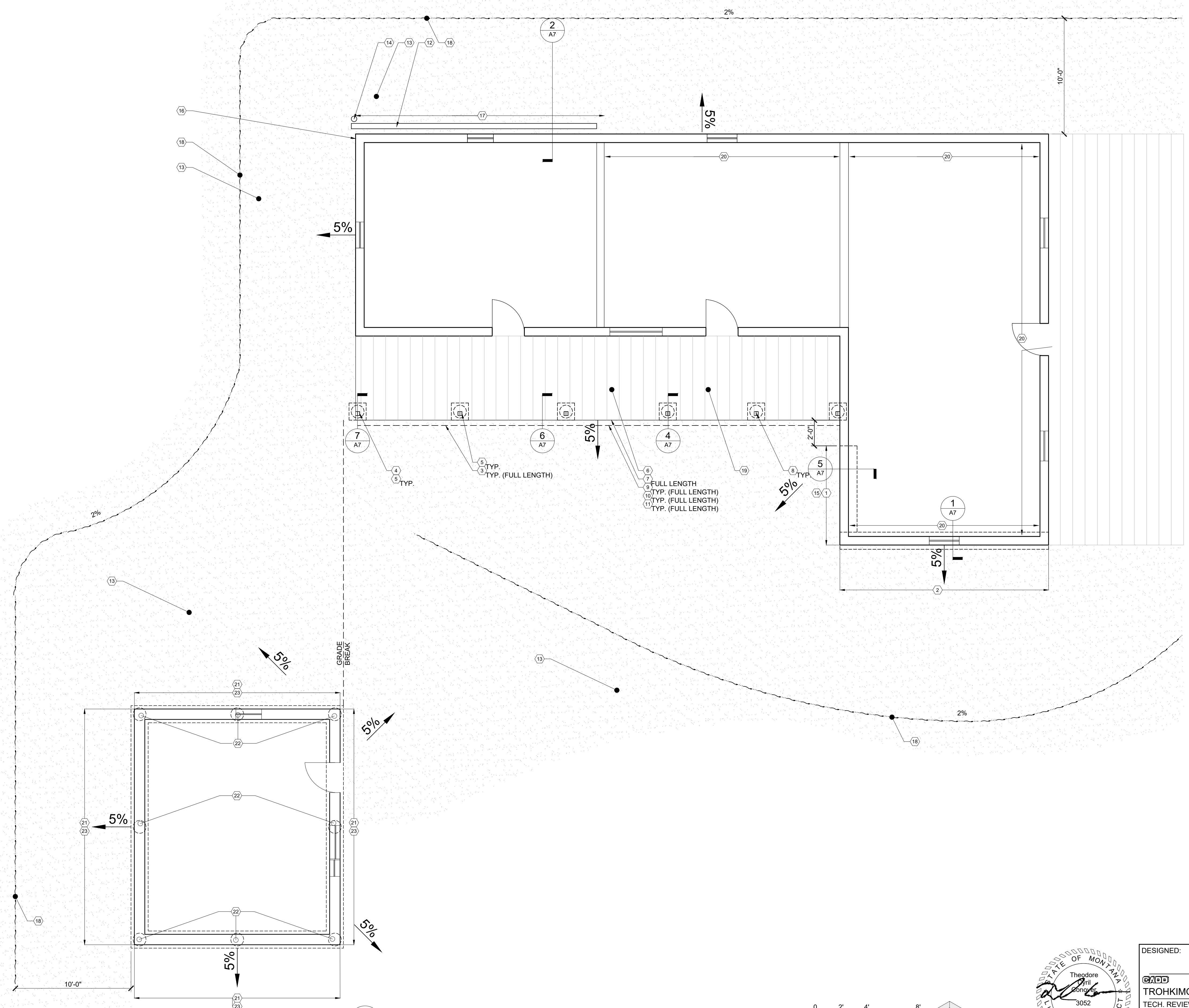

1  
A2

MAIN LEVEL PLAN

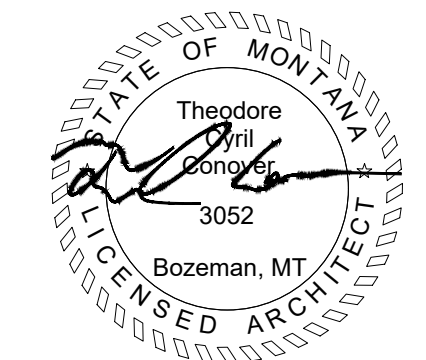
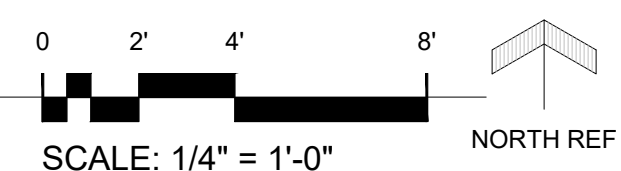

DESIGNED: TROHKIMOINEN	SUB SHEET NO. <b>A2</b>	TITLE OF SHEET <b>CHIEFS HOUSE &amp; STORE FOUNDATION PLAN</b>	DRAWING NO. _____
TECH. REVIEW: HOLLING		CHIEF PLENTY COUPS STATE PARK	PKG. NO. _____ SHEET <b>2</b> OF <b>7</b>
DATE: 08.24.2022			





CHIEF'S HOUSE SOUTHWEST CORNER WITH SETTLING

1  
A3



CHIEF'S HOUSE LEAVES PILED UP IN FRONT OF SOUTH PORCH

2  
A3



CHIEF'S HOUSE, EARTH SLOPING DOWN TOWARDS NORTH SIDE OF BUILDING

3  
A3



CHIEF'S HOUSE DOWNSPOUT AT SOUTHWEST CORNER

4  
A3



CHIEF'S HOUSE SETTLING AT INTERIOR SOUTHWEST CORNER

5  
A3



CHIEF'S HOUSE TYPICAL EAVE & GUTTER (NORTH)

6  
A3



CHIEF'S HOUSE TYPICAL EAVE & GUTTER (SOUTH)

7  
A3



NORTHWEST CORNER, SHOWING EARTH SLOPING DOWN TOWARDS WEST SIDE ON BUILDINGS

8  
A3

GENERAL SHEET NOTES

1. SEE GENERAL PROJECT NOTES ON COVER SHEET.
2. SEE OTHER SHEETS IN THIS SET FOR ADDITIONAL INFORMATION.
3. SENSITIVE CULTURAL RESOURCES ARE KNOWN TO BE PRESENT. DO NOT DISTURB AND ALERT MONITORING ARCHEOLOGIST IF ANY ARTIFACTS OR OTHER CULTURAL ITEMS ARE ENCOUNTERED.
4. TRIBAL AND HERITAGE ARCHEOLOGISTS TO BE ON-SITE DURING ALL GROUND DISTURBANCES.
5. ALL GRADING TO BE DONE BY HAND.
6. FLAG SPRINKLER SYSTEM LINES AND HEADS PRIOR TO ANY WORK TO AVOID DAMAGING THE SYSTEM.

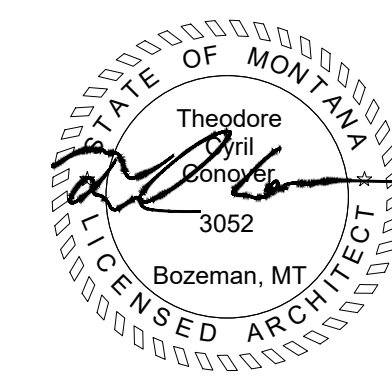

DESIGNED:  
TROHKIMOINEN  
TECH. REVIEW:  
HOLLING  
DATE:  
08.24.2022

SUB SHEET NO.  
**A3**

TITLE OF SHEET  
**CHIEF'S HOUSE PHOTOS**  
CHIEF PLENTY COUPS STATE PARK

DRAWING NO.  
\_\_\_\_\_  
PKG. NO. \_\_\_\_\_  
SHEET  
**3**  
OF  
**7**



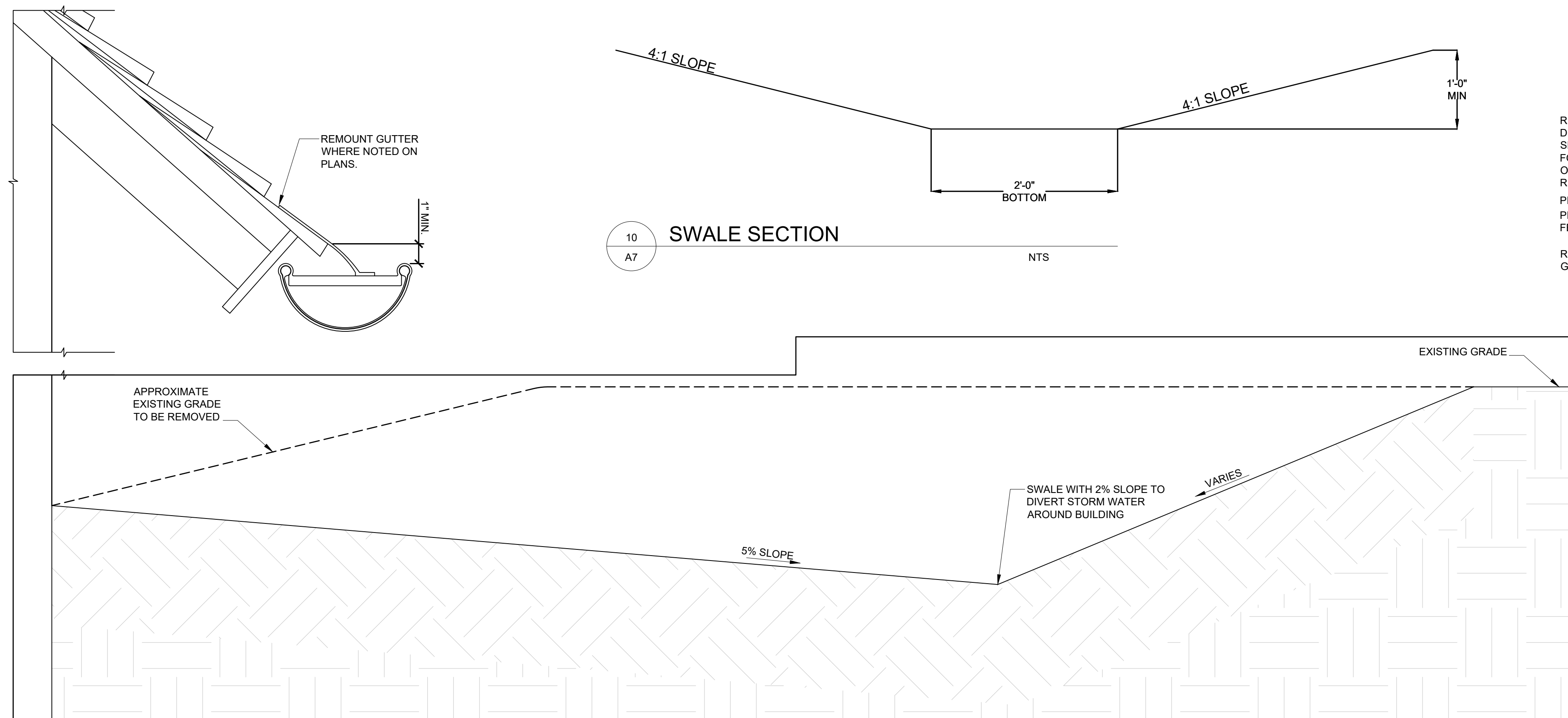

10 SWALE SECTION  
A7 NTS

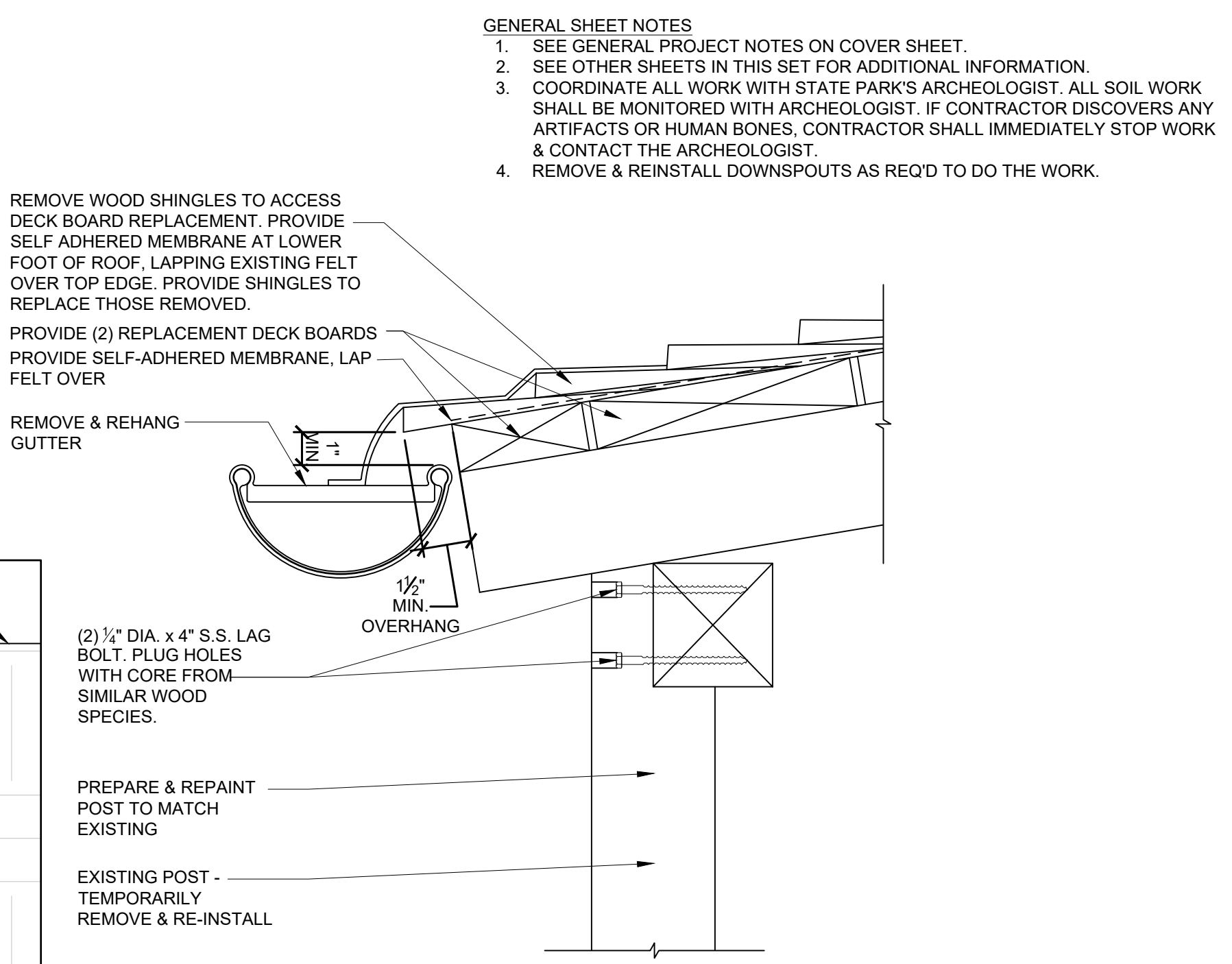

6 SOUTH EAVE DETAIL  
A7

0 6" 1'  
SCALE: 3" = 1'-0"

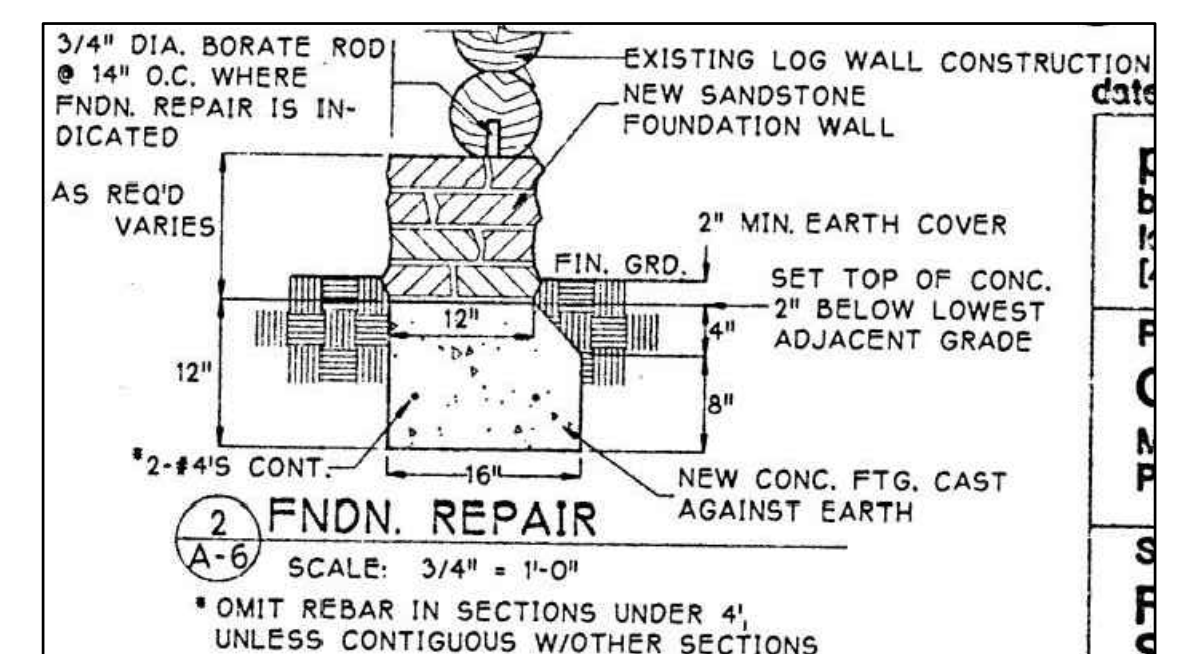

1 1993 FOUNDATION REPAIR DETAIL FOR INFORMATION  
A7 NTS

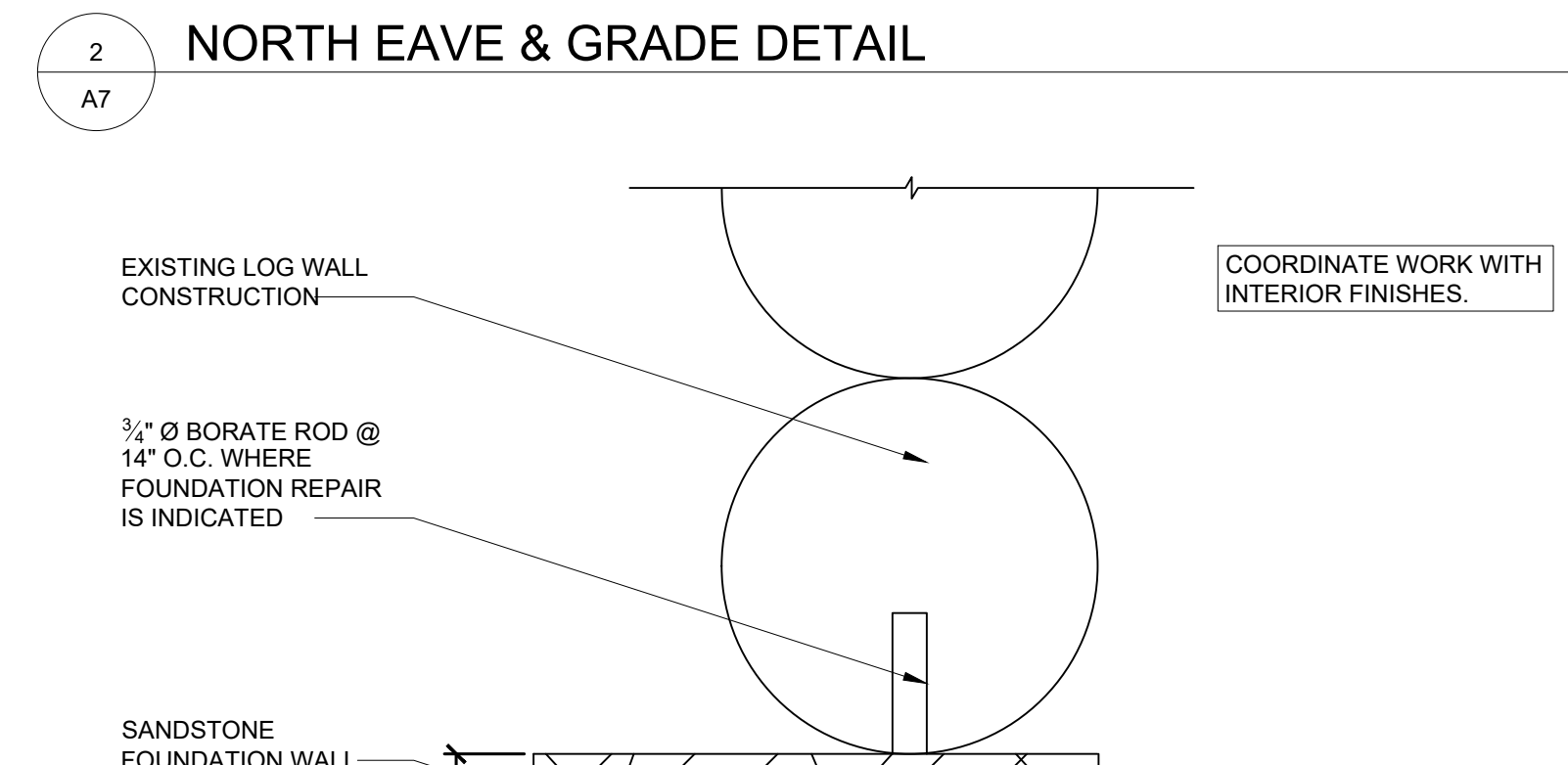

2 NORTH EAVE & GRADE DETAIL  
A7

0 6" 1'  
SCALE: 3" = 1'-0"

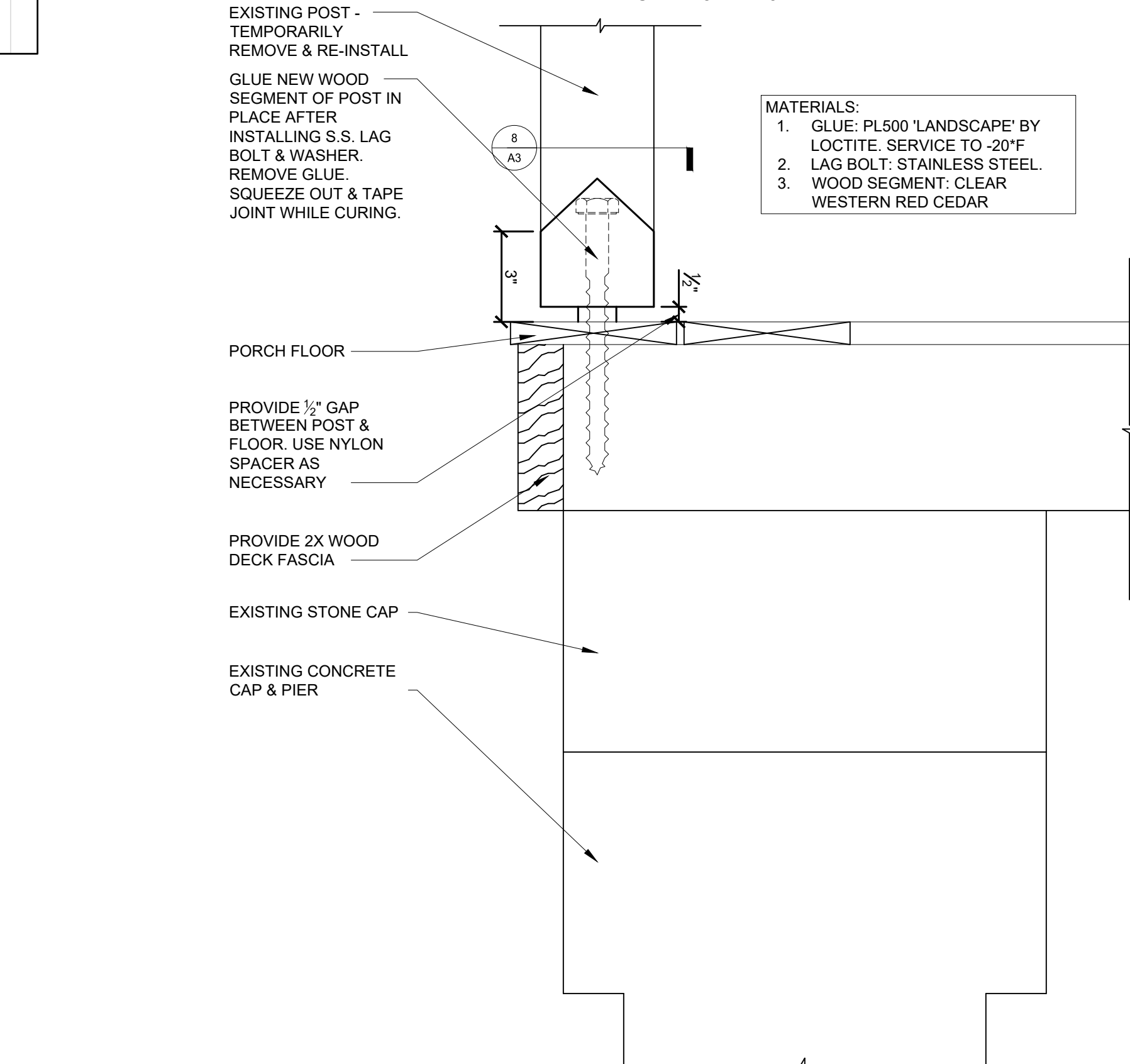

7 PORCH PIER DETAIL  
A7

0 6" 1'  
SCALE: 3" = 1'-0"

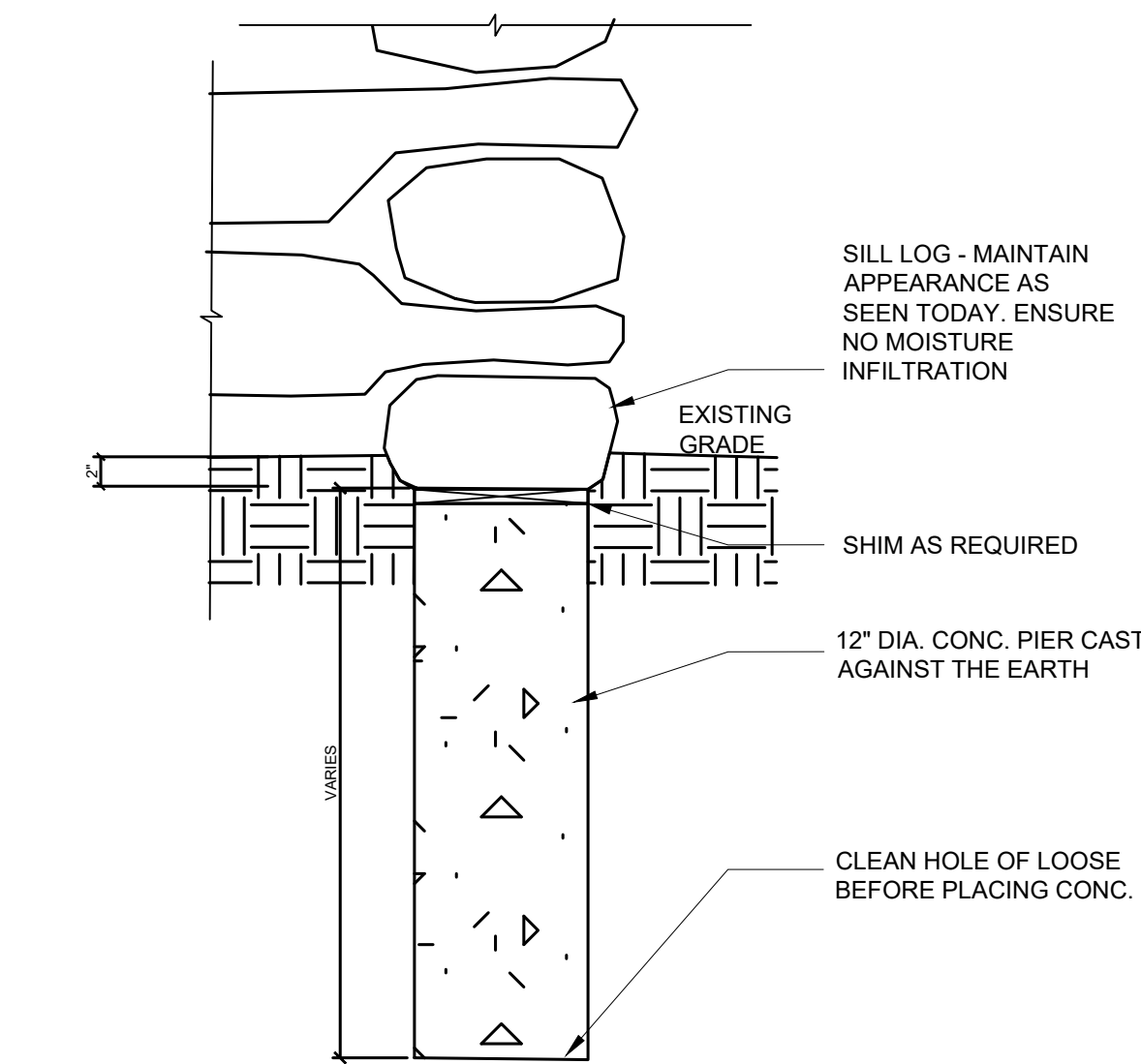

4 PIER DETAIL  
A7 NTS

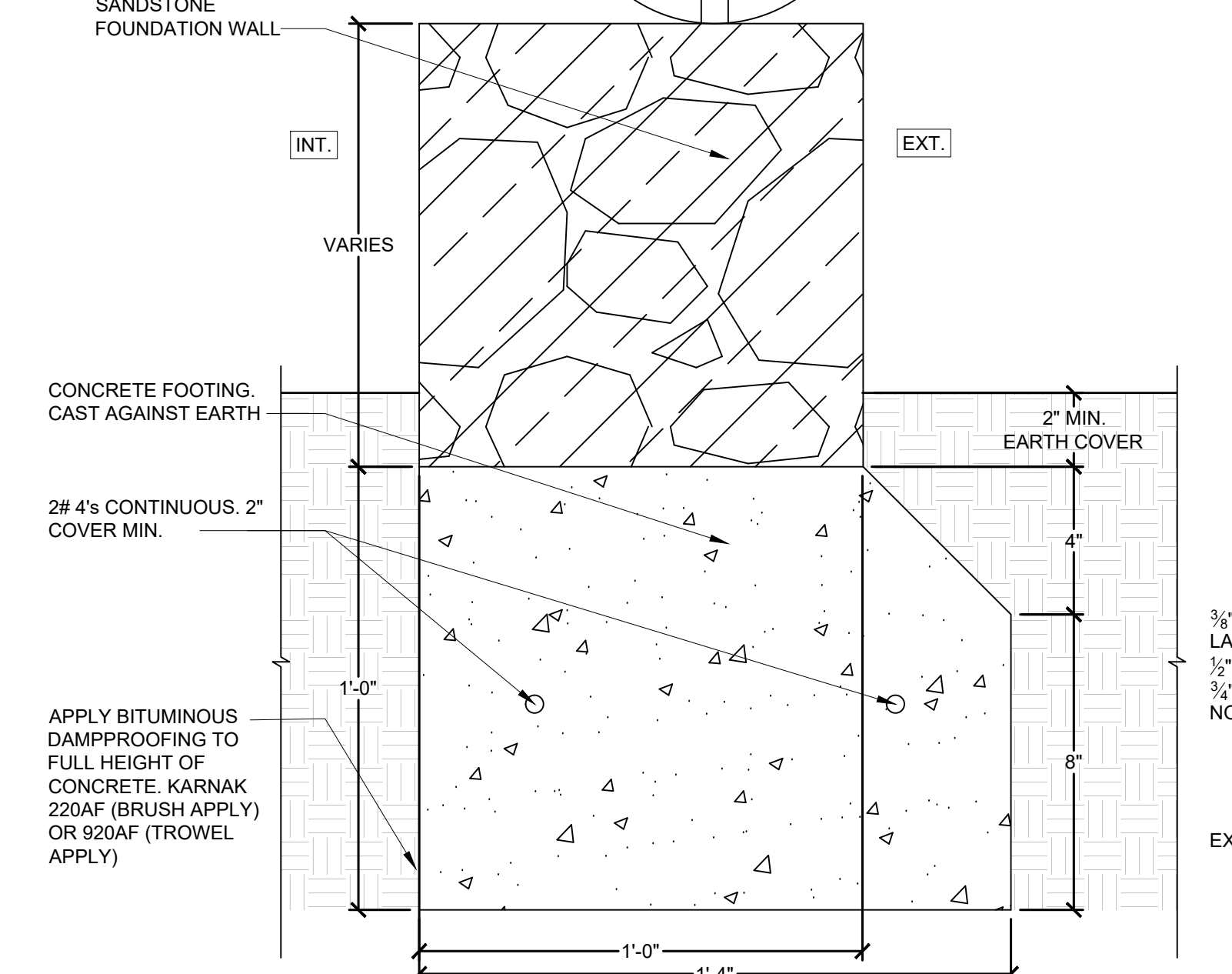

5 FOUNDATION REPAIR DETAIL  
A7

0 6" 1'  
SCALE: 3" = 1'-0"

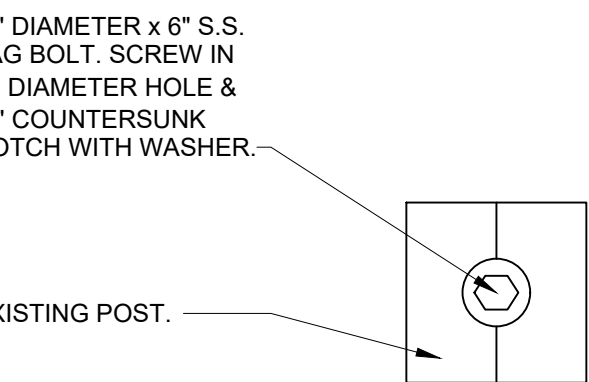

8 LAG BOLT DETAIL  
A7

0 6" 1'  
SCALE: 3" = 1'-0"

- GENERAL SHEET NOTES
1. SEE GENERAL PROJECT NOTES ON COVER SHEET.
  2. SEE OTHER SHEETS IN THIS SET FOR ADDITIONAL INFORMATION.
  3. COORDINATE ALL WORK WITH STATE PARK'S ARCHEOLOGIST. ALL SOIL WORK SHALL BE MONITORED WITH ARCHEOLOGIST. IF CONTRACTOR DISCOVERS ANY ARTIFACTS OR HUMAN BONES, CONTRACTOR SHALL IMMEDIATELY STOP WORK & CONTACT THE ARCHEOLOGIST.
  4. REMOVE & REINSTALL DOWNSPOUTS AS REQ'D TO DO THE WORK.

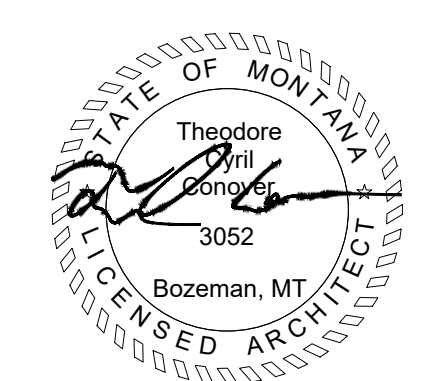

DESIGNED: TROHKIMOINEN	SUB SHEET NO. <b>A4</b>	TITLE OF SHEET <b>DETAILS</b>	DRAWING NO.
TECH. REVIEW: HOLLING		CHIEF PLENTY COUPS STATE PARK	PKG. NO.
DATE: 08.24.2022			SHEET <b>4</b>
			OF <b>7</b>